

## **Effect on Measured Hearing Threshold of Low Frequency Noise by Various Test Methods**

Toshiya KITAMURA<sup>1</sup>, Yoshitaka ASHIKAWA<sup>2</sup>, Shinji YAMADA<sup>3</sup>, Satoshi YAMADA<sup>4</sup>

<sup>1</sup> University of YAMANASHI, Graduate Faculty of Interdisciplinary Research, Yamanashi, Japan  
(corresponding author)

<sup>2</sup> University of YAMANASHI, Department of Mechatronics, Yamanashi, Japan

<sup>3</sup> University of YAMANASHI, Professor Emeritus, Yamanashi, Japan

<sup>4</sup> INZX Co. LTD, Tokyo, Japan

Corresponding author's e-mail address: [kitamura@yamanashi.ac.jp](mailto:kitamura@yamanashi.ac.jp)

### **ABSTRACT**

We measured hearing thresholds of low frequency sound of 20 subjects with various test methods and evaluated influences on measured hearing thresholds by test factors of the methods. All tested methods are based on up-down method. The test factors are a wave form as “Continuous” or “Intermittent”, level change rate, number of trials, one cycle time of intermittent test sounds, duty cycle of intermittent test sound, flat ratio of intermittent test sound and up-down alternate way or up way only. The tested frequencies are 16, 31.5 and 63Hz as central frequency of 1/1 octave band. In order to investigate what is the factor that gives fluctuation to the threshold level, the average threshold levels and standard deviations according to each conditions were compared and the reliability was confirmed with t-test. In order to estimate the magnitude of the error of the up only method applying complainers who feel strong pain to low frequency noise, the difference between measured level by the up only method and up-down method was also evaluated.

### **BACKGROUND AND TEST METHOD**

We have been studying psychological and physiological effects of low frequency noise. For evaluation of individuals responses to low frequency sound correctly, hearing thresholds of all subjects are measured before objective experiments. Once in a while, the measurement systems and test ways were renewed for any purpose of the tests and for shortening of test times. The threshold values changed a little at renewal of the measurement ways. We anticipate that the change is caused by an influence of difference of subject's response delay by change of measurement ways. We have been using up-down method for measuring threshold by ordinary, but some subjects who are complaints of low frequency noise allowed up method only because they feel dislike stronger on low frequency noise than other common subjects and they reject a level inconsiderably over their thresholds. We had dubiety on correctness of these measured thresholds.

Therefore we evaluate differences and variances of thresholds of low frequency sound by measurement ways.

Test methods in this paper are based on up-down method. 3 frequencies 11 conditions, totally 33 tests were done on a subject. Some conditions of environments are not adapted to ISO 8253. Especially, the size of the low frequency sound chamber is smaller than the ISO, because a small chamber is of advantage to generate high level low frequency sound and to make uniform pressure level. As a result, the distance between loud speakers and ears of subject are near than the specified distance in the ISO.

**Presentation sounds.**

The presentation sounds are increasing or decreasing level and continuous or intermittent pure tone sound. Frequencies of the sounds are 16Hz, 31.5Hz and 63Hz as central frequency of 1/1 octave band. The other parameters of the test sounds are shown in Table 1. 11 conditions are combined these parameters with red values as reference in the table.

**Table 1:** Conditions of test sounds

|                                 | Continuous sound      | Intermittent sound     |
|---------------------------------|-----------------------|------------------------|
| Sound frequency                 | 16Hz, 31.5Hz, 64Hz    | 16Hz, 31.5Hz, 64Hz     |
| Trial Number                    | 5, 11                 | 5, 11                  |
| Level change rate               | 0.5dB/s, 1dB/s, 2dB/s | 0.5dB/cycle, 1dB/cycle |
| Intermittent frequency          | -                     | 0.5s, 1s, 2s           |
| Duty of intermittent sound      | -                     | 25%, 50%               |
| Flat rate of intermittent sound | -                     | 25%, 50%               |

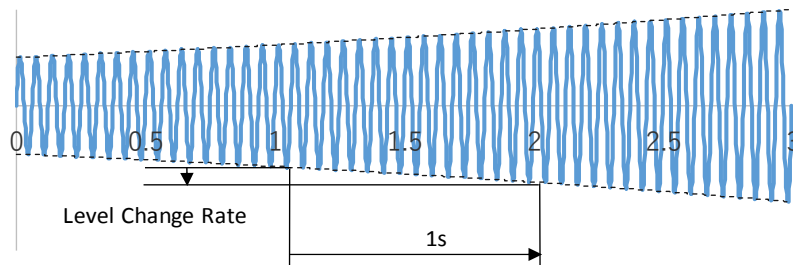

**Figure 1:** Time Wave Form of Continuous sound

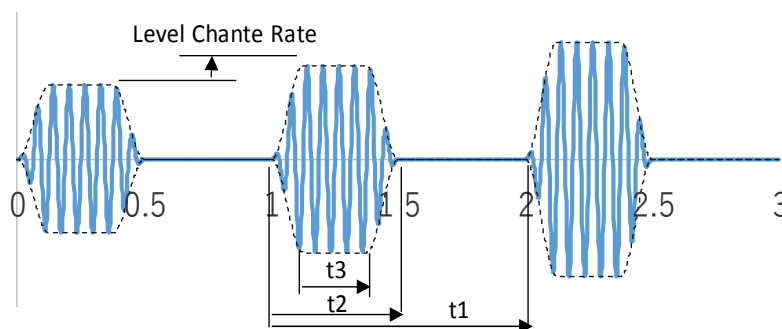

**Figure 2:** Time Wave Form of Intermittent sound

The images of time wave form of continuous and intermittent are shown in Figure 1 and 2 each. At Figure 1,  $t_1$  is the intermittent period. The duty of intermittent sound is obtained by Equation 1.

$$\text{Duty} = \frac{t_2}{t_1} \times 100 \text{ [\%]} \quad (1)$$

The Flat rate of intermittent sound is obtained by Equation 2.

$$\text{Flat rate} = \frac{t_3}{t_2} \times 100 \text{ [\%]} \quad (2)$$

### Test setup

An Experimental Setup is shown in Figure 3. A control PC generates test sound signals and outputs the signal to an audio equipment (Sound Blaster Audigy 2 NX) via a USB port by 24bits 44.1kHz digital. The test sound signal are played into a low frequency sound chamber by three 450mm diameter motion feedback loud speakers driven by an amplifier. A subject responds with a push button connected to the control PC via a PIC MPU board and USB port. Sound pressure level inside the chamber is measured with a microphone of sound level meter being set close to the subject right ear and monitored by an indicator of the sound level meter and a signal analyser. An Operator can talk to a subject by a set of transceivers. The low frequency sound chamber shown in Figure 4 has 735mm(W) \* 1710 mm(H) \* 725mm(D) and is set in a soundproof chamber.

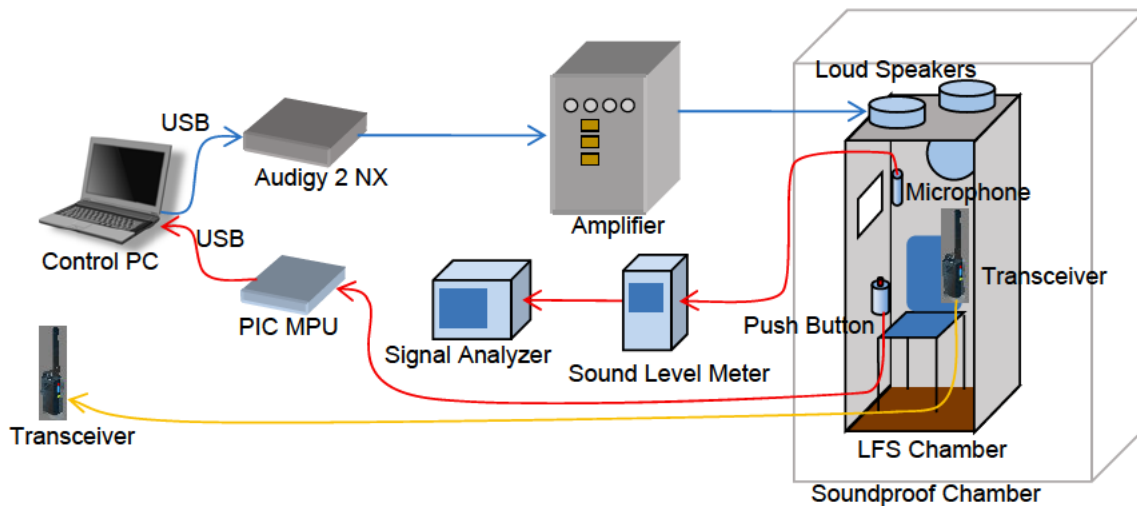

Figure 3: Experimental Setup



Figure 4: Low Frequency Sound Chamber and Subject

## Experiment procedures

An experiment procedure is shown in below.

### Preparations

1. The control PC output 16Hz sinusoidal wave as maximum level. The sound level in the low frequency chamber is levelled more than 15dB higher than general threshold level by the amplifier volume controls. The volume is kept during the day.
2. The levels of 16, 31.5 and 63Hz at the setting are measured exactly.
3. We give brief explanation about object, outline and procedure of this experiment and liberty to interrupt or break the test to subjects.
4. The subject sits on a chair in the chamber with the switch and the transceiver in his/her hands. The position of the microphone of sound level meter is moved close to the subject ear.

### Test process

1. As 1<sup>st</sup> trial, the operator announce to the subject 'Push the switch, when you feel low frequency sound'. A test sound levelled 20dB less than the general threshold level or ISO threshold level is outputted and is increased by prescribed level change rate. When the subject push the switch, outputting level is recorded and stop the sound by the system.
2. As 2<sup>nd</sup> trial, the operator announce 'Push the switch, when you lose low frequency sound feeling'. A test sound is outputted as 5dB higher than last recorded level and then it decreases. The outputting level is recorded when the subject push the switch.
3. As 3<sup>rd</sup> trial, whole procedures are the same as 1<sup>st</sup> trial, but initial output level is 10dB less than last recorded.
4. Similar procedures of 2<sup>nd</sup> and 3<sup>rd</sup> trial are done until set number.
5. After finishing all trials, the average level from the 2<sup>nd</sup> trial to last trial is calculated as temporary threshold. The operator announce 'wait a moment quietly'. The sinusoidal wave levelled 10dB less than the temporary threshold level is output to the chamber and is measured the sound pressure level in the chamber. The final threshold level is corrected by the difference of measured level.

Orders of tests were decided randomly to avoid an influence of a previous test. Total time to test a subject is 2 hour or more, so subject took a break every 30 minutes. Data, which have more than 10dB error between the final threshold level and the temporary threshold level, were eliminated as low reliability data.

## RESULTS OF MEASUREMENTS

Table 2 shows test codes, the corresponding conditions, thresholds by the condition and the thresholds of ISO. Figure 5 show the chart of the Table 2 and the differences to the average at 16Hz or the thresholds of ISO 389-7 at 31.5 and 63Hz. The test codes are describe "C-[Level Change Rate]-[Number of Trials]" for continuous conditions and "I-[Level Change Rate]-[Number of Trials]-[Frequency of Intermittent]-[Duty Cycle (%)]-[Flat Ratio (%)]" for intermittent conditions as test codes. Averages of whole tests are 82.59dB at 16Hz, 60.32dB at 31.5Hz and 35.83dB at 63Hz. The results of 31.5Hz and 63Hz are nearly equal level to ISO 389-7. Widths between maximum and minimum of 16 and 31.5Hz are small as about 2.2dB, but of

63Hz is wider as 6.1dB. The results of 63Hz can be grouped by the tests of using continuous sound locating about 38dB and by these using intermittent sound locating about 34dB. By t-test between reference test coded “C-1-5” or “I-1-5-1-50-50”, there is no difference in the whole thresholds except for the difference between using continuous sound and using intermittent sound at 63Hz.

**Table 2: All Averaged Thresholds and ISO 389-7**

| Test Code        | Test Conditions |                                     |                  |                    |                |                | Averaged Threshold [dB] |         |       |
|------------------|-----------------|-------------------------------------|------------------|--------------------|----------------|----------------|-------------------------|---------|-------|
|                  | Test Sound type | Level Change Rate [dB/s] [dB/cycle] | Number Of Trials | One Cycle Time [s] | Duty Cycle [%] | Flat Ratio [%] | 16 Hz                   | 31.5 Hz | 63 Hz |
| C-0.5-5          | Continuous      | 0.5                                 | 5                |                    |                |                | 83.09                   | 59.98   | 39.67 |
| C-1-5            |                 | 1                                   | 5                |                    |                |                | 81.96                   | 60.87   | 38.17 |
| C-2-5            |                 | 2                                   | 5                |                    |                |                | 81.02                   | 60.50   | 38.61 |
| C-1-11           |                 | 1                                   | 11               |                    |                |                | 83.10                   | 60.81   | 37.04 |
| I-0.5-5-1-50-50  | Intermittent    | 0.5                                 | 5                | 1                  | 50             | 50             | 83.07                   | 60.14   | 33.52 |
| I-1-5-1-50-50    |                 | 1                                   | 5                | 1                  | 50             | 50             | 82.93                   | 59.90   | 33.85 |
| I-1-11-1-50-50   |                 | 1                                   | 11               | 1                  | 50             | 50             | 83.32                   | 59.85   | 34.27 |
| I-1-5-0.5-50-50  |                 | 1                                   | 5                | 0.5                | 50             | 50             | 83.03                   | 61.16   | 34.67 |
| I-1-5-2-50-50    |                 | 1                                   | 5                | 2                  | 50             | 50             | 81.43                   | 59.02   | 35.50 |
| I-1-5-1-25-50    |                 | 1                                   | 5                | 1                  | 25             | 50             | 82.31                   | 60.65   | 33.56 |
| I-1-5-1-50-25    |                 | 1                                   | 5                | 1                  | 50             | 25             | 83.20                   | 60.61   | 35.30 |
| Average of Tests |                 |                                     |                  |                    |                |                | 82.59                   | 60.32   | 35.83 |
| ISO 389-7        |                 |                                     |                  |                    |                |                | 59.5                    | 37.5    |       |

Yellow: minimum, Orange: maximum

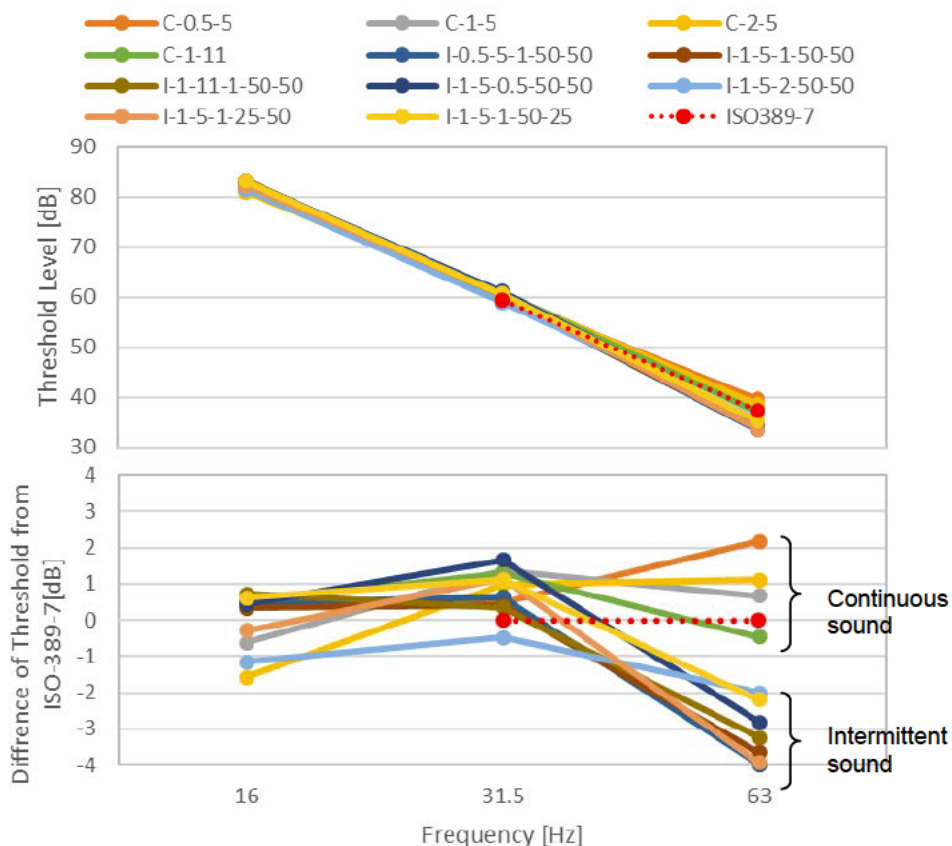
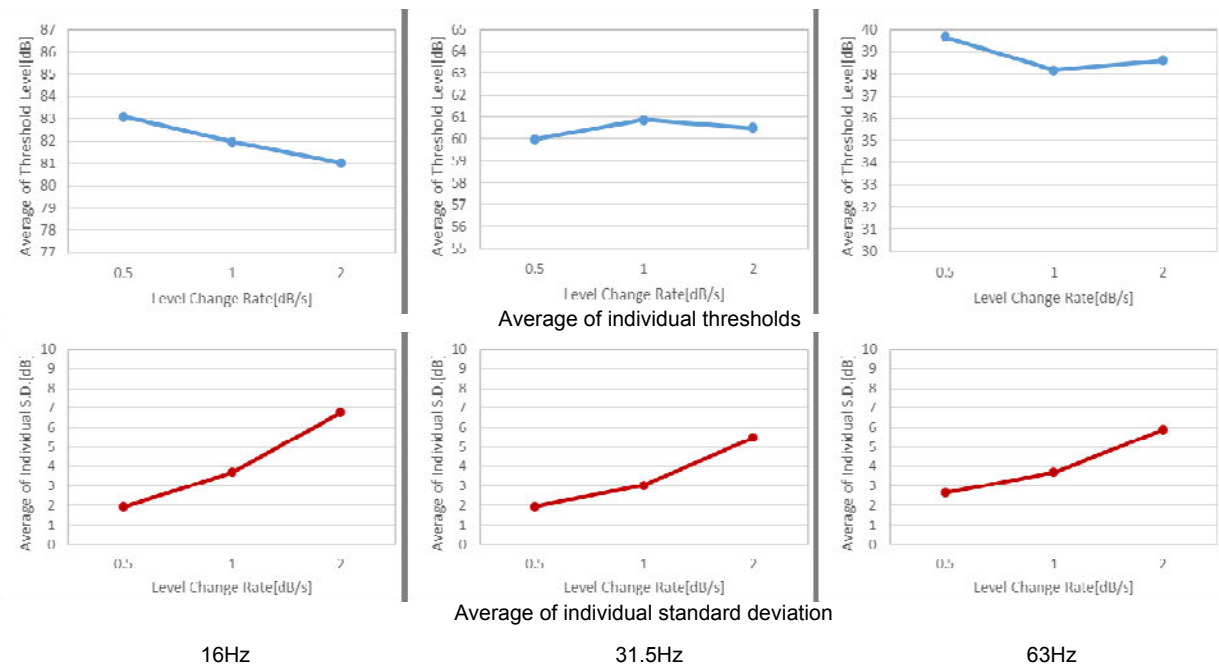

**Figure 5: Thresholds of All Test Conditions and Difference from Average**

## Influences of test sound

We evaluated influences of each parameters. Typical charts are shown in Figure 6, 8 and 9. These charts show the average value of the threshold level of each subjects in upper row and the average of individual standard deviation (S.D.) in lower row. 16Hz, 31.5Hz, 63Hz are displayed in order from the left.

Figure 6 shows influence of “Level change rate” at continuous test sound, 5 trials. A test sound at 2dB/s increase or decrease the level faster than at 0.5dB/s. The changes in the average of threshold are as small as 2dB. Although the average of threshold decrease according to the level change rate in the 16Hz, we were unable to find the influence on the



**Figure 6:** Influence of level change rate at continuous test sound

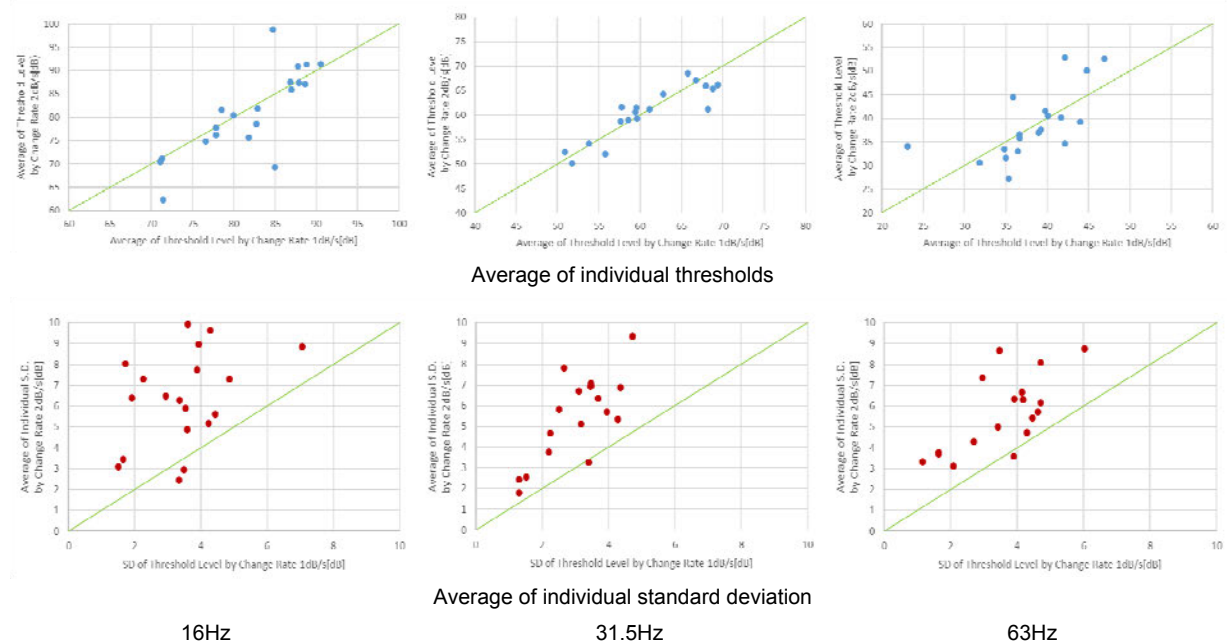

**Figure 7:** Distribution of Individual Threshold and Standard Deviation at level change rate 1dB/s vs 2dB/s

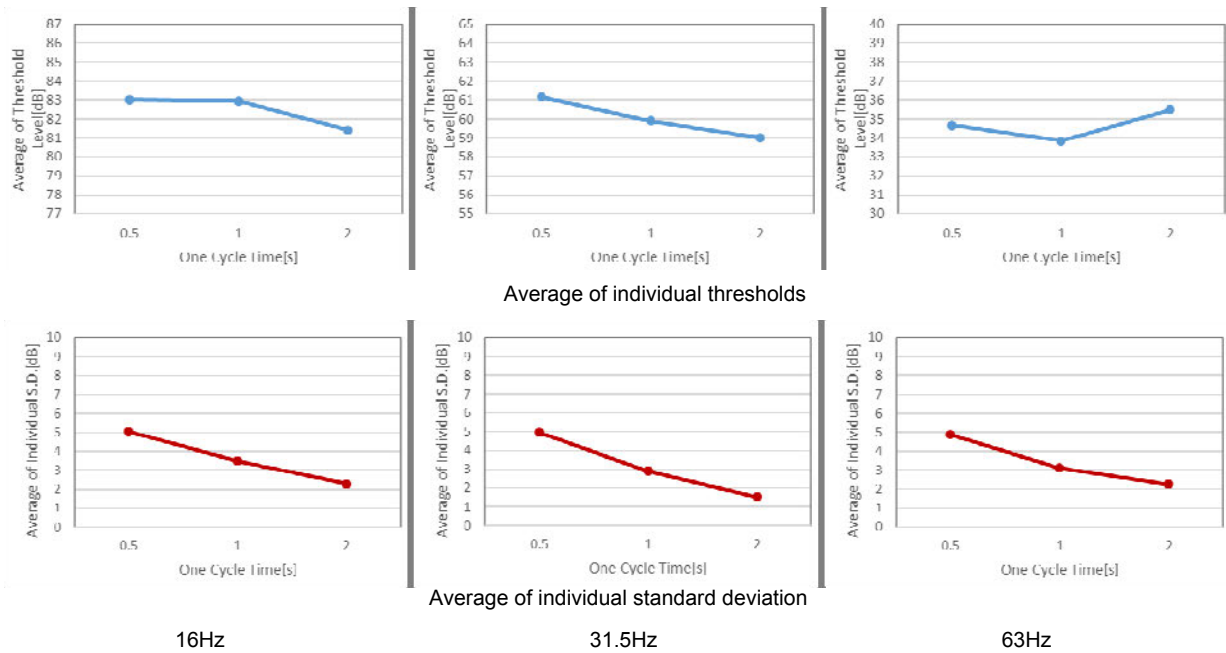

**Figure 8:** Influence of one cycle time at intermittent test sound

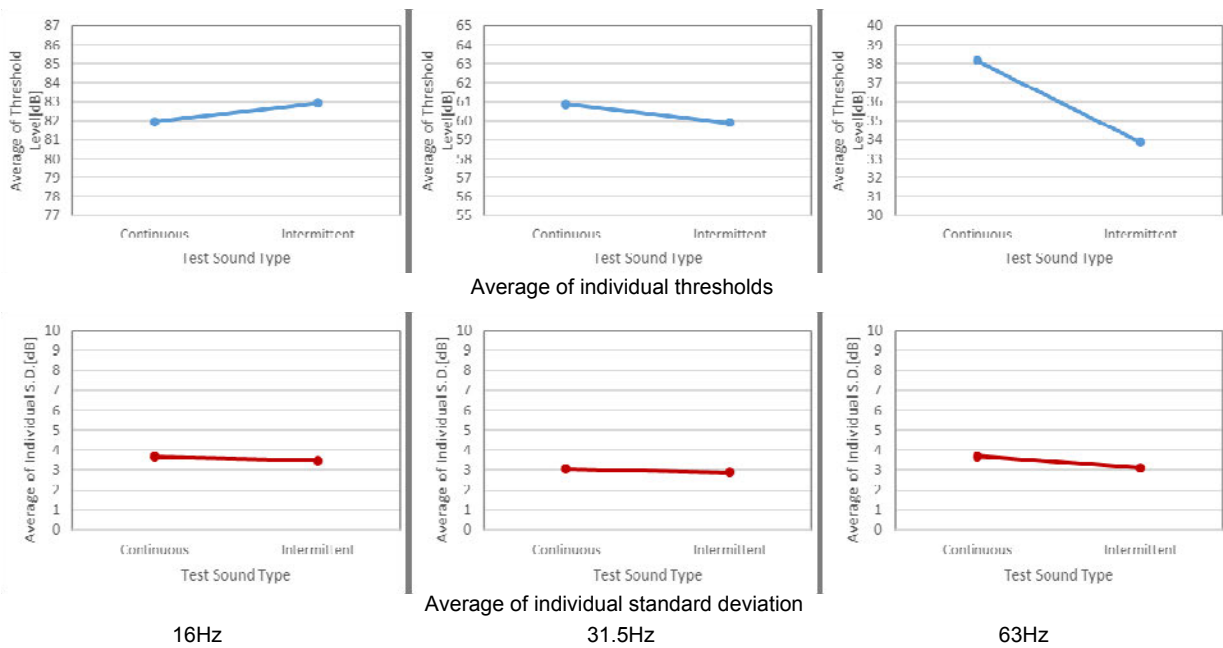

**Figure 9:** Influence of test sound type as continuous or intermittent

average of thresholds. However, the averages of individual standard deviation increase according to the level change rate.

Figure 7 shows distributions of individual thresholds and standard deviation by the same condition of the Figure 6. Upper row shows the distributions of threshold and the lower row shows the standard deviation. 16Hz, 31.5Hz, 63Hz are shown in order from the left. The horizontal axis is the individual threshold or standard deviation at level change rate 1dB/s and the vertical axis is at 2dB/s. The green line mean the values of 1dB/s and 2dB/s are the same. The averages distributed almost on the green line. The standard deviations is widely distributed above the green line. It mean that a faster change in level made the response of subjects unstable.

Figure 8 shows the influence of the change in "One cycle time" at intermittent test sound, 5 trials, 50% duty, 50% flat ratio. The one cycle time 0.5s is shorter presentation time and faster

change of the level than the 2s. The changes in the average of thresholds were as small as 2dB and were not affected by the “One cycle time”. However, the averages of individual standard deviations decrease as one cycle time increases.

Figure 6 and 8 say that the faster change of level and short presentation time increase the variation in the level of perception of low frequency sound.

Figure 9 shows the influence of test sound type of “Continuous (C-1-5)” or “Intermittent (I-1-5-1-50-50)”. Although the changes of 16 and 31.5Hz were as small as 1dB, the change of 63Hz was as large as 4.3dB. The averages of individual standard deviation was almost constant as 3 to 4dB.

We were unable to find any influences of other parameters.

### Error of up only method

The data by up method extracted from 11 trials test were evaluated as data of up only method. The average thresholds are shown in Figure 10. There is a difference of about 2.8dB between the extracted data and whole data.

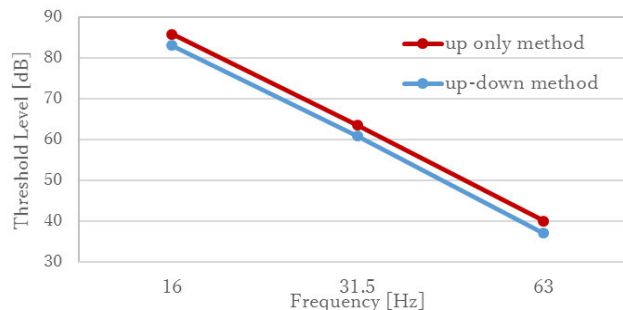

**Figure 10:** Difference between up only method and up-down method.

## CONCLUSION

We evaluated differences of the thresholds by the various test sound at 16, 31.5 and 63Hz.

The difference of minimum to maximum were in about 2dB at 16Hz and 31.5Hz, however the difference of 63Hz was in about 6dB. The cause of the large difference at 63Hz was whether the type of tests sound were continuous or intermittent. The continuous test sounds increased the threshold by 4dB or more from the intermittent test sounds.

The change in thresholds due to the level change rate and the time of 1 cycle were small, although the standard deviations increased as faster level change or short display time.

In the case of only the up method, the threshold was about 3dB higher than the up-down method.

ISO method is by intermittent sound. In many real cases of low frequency noise the sound sources are continuous and the complainants commonly claim the continuous noise. In some countries the recommended level on low frequency noise are decided and the level sometimes is based on the ISO threshold. But as in this experiment at 63Hz the thresholds are different according the methods. In Sweden and in Japan the reference value are separated gradually from the ISO threshold according to the high frequencies. One reason of this separation is the threshold difference according to the sound characters.

### Acknowledgements

The authors would like to thank H. SAEGUSA for experiment supports. We also thank all subjects.